

X99® Seminar - Torsion Spring Cover Replacement

For chairs Manufactured Pre-2006

Installation Instructions

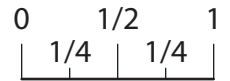

Scale 1 : 1

Tools Required

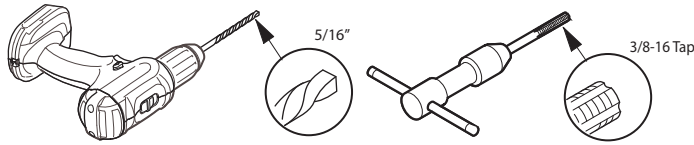

1 Remove screws (S-31) and broken torsion spring cover (A).

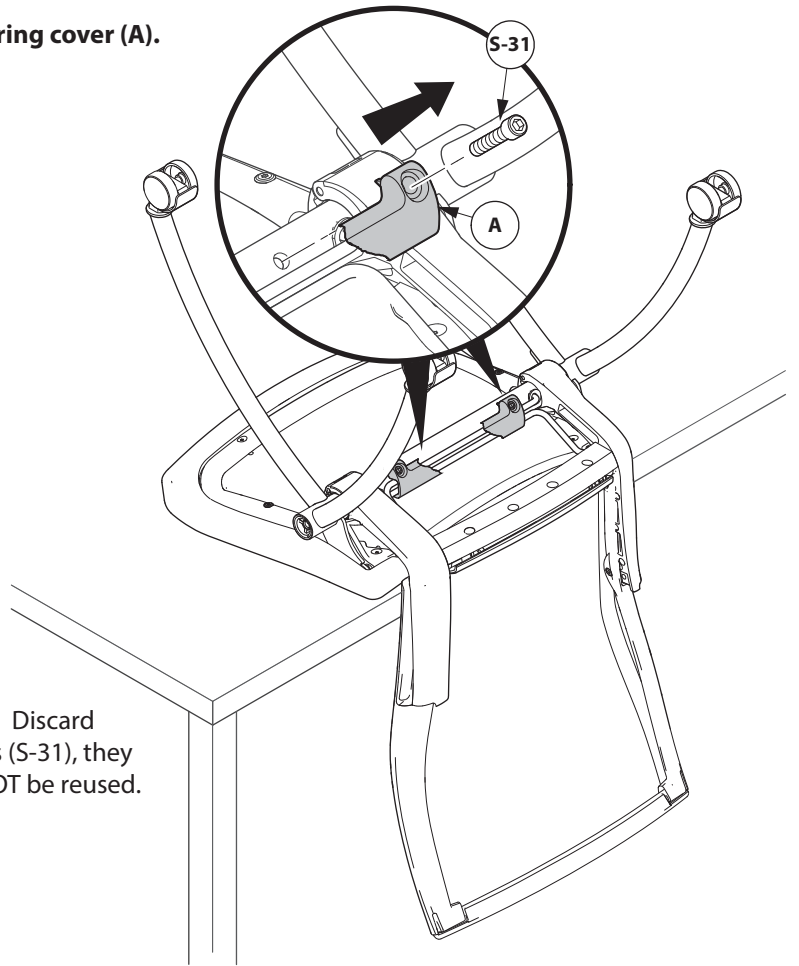
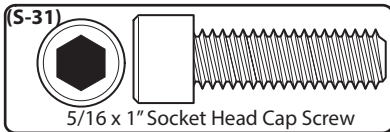
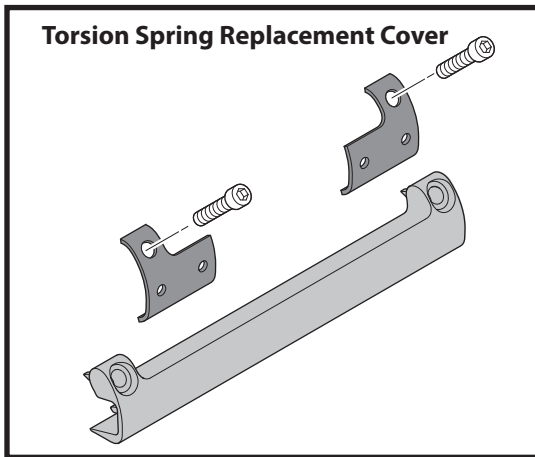

NOTE: Discard screws (S-31), they will NOT be reused.

2 Remove torsion springs (B).

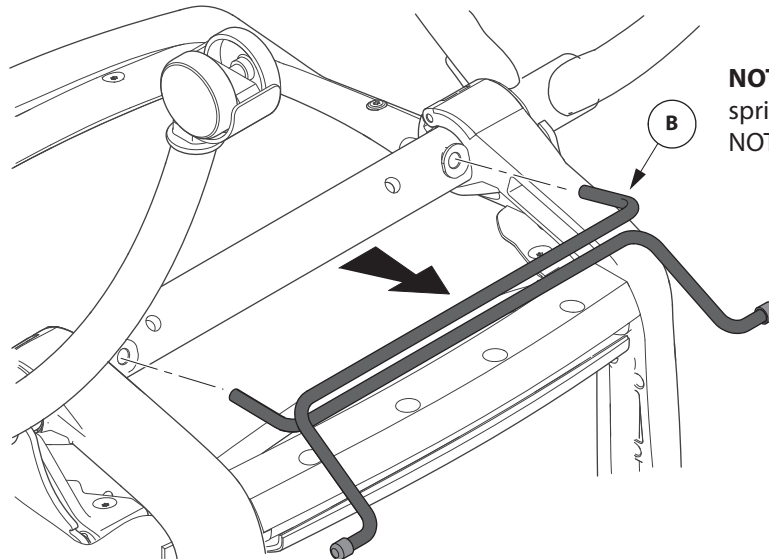

NOTE: Discard torsion springs (B), they will NOT be reused.

CUSTOMER SERVICE PHONE: 1-800-426-8562

HAWORTH®

E.C.O. No: 000-000

Page: 1 of 2

Part No: 0000-0000

Rev: x1

3

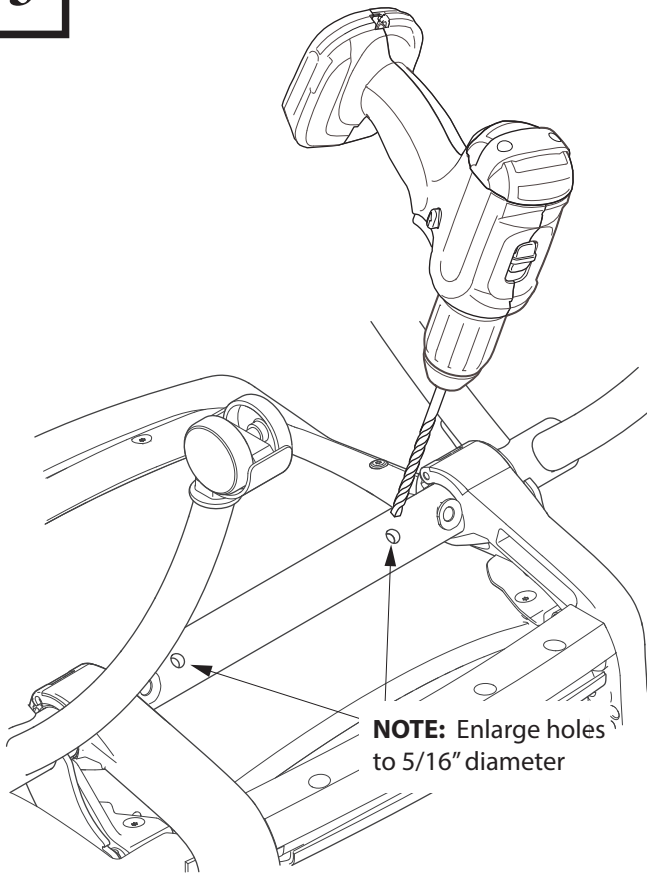

4

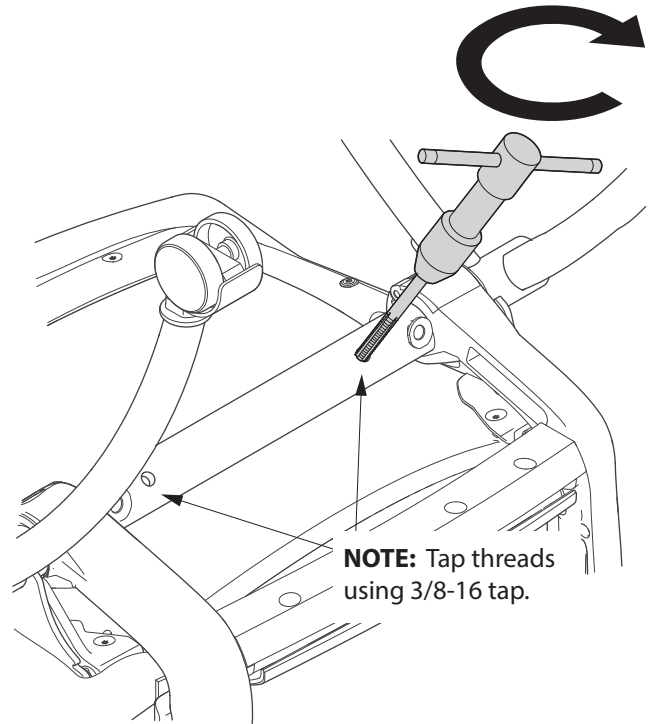

5

Install new torsion springs (C).

NOTE: Make certain plastic spring bushings are in place, existing or new can be used.

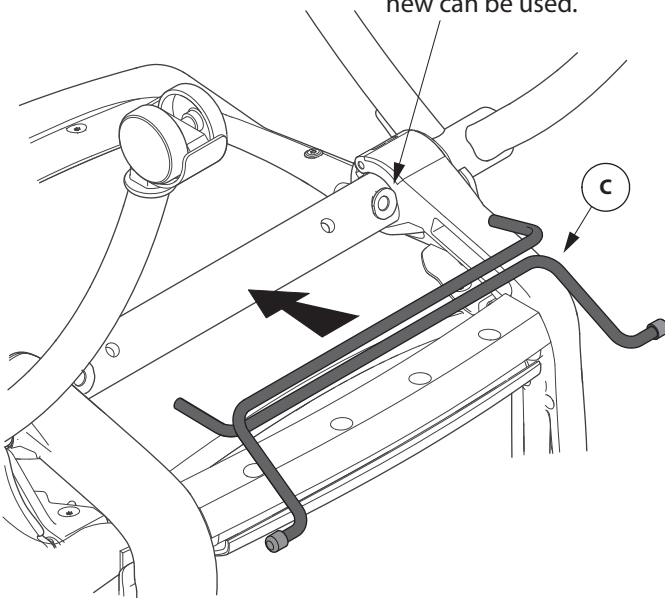

6

Install new torsion spring cover (D) using 3/8 x 1" screw (S-35).

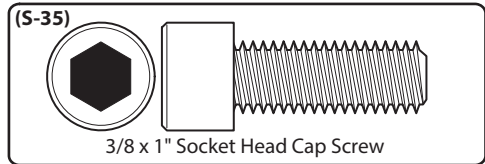
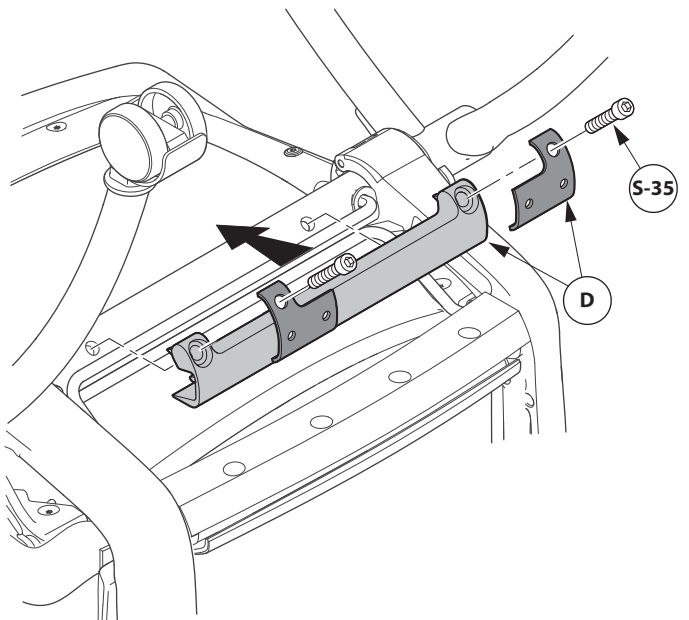

CUSTOMER SERVICE PHONE: 1-800-426-8562